



MIMO Srl divisione ALLEN

Via dell'Industria, 36 - 35020 – BRUGINE (PD) Italy - Tel. +39 049 5806061 Fax: +39 049 5806611
info@allentechnology.it - www.allentechnology.it

Mechanical, hydropneumatic and hydraulic vices for drills and drilling/milling machines

MPT/58 MECHANICAL VICE

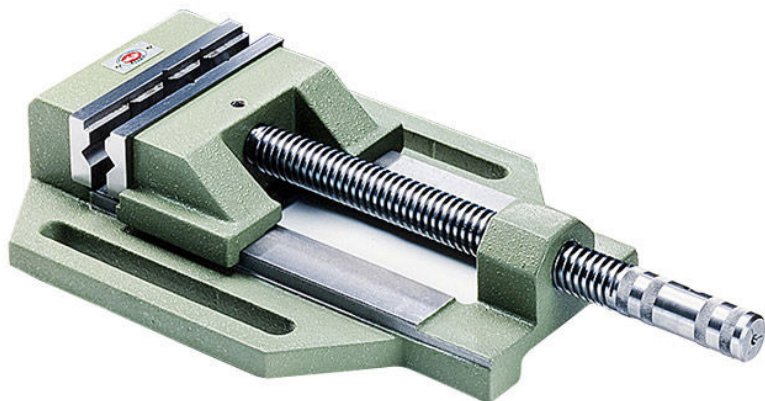

Material

G26 CAST IRON UNI 5007

Caratteristiche

BREAKING LOAD: Rmin = 26

ELONGATION %: A% = 1

An extremely handy vice suitable for all light machining such as adjustments, drilling, threading with threading machines, cutting-off machines and all kinds of drilling machines. It can be supplied either with flat ground jaws made of casehardened and tempered steel or with indented prismatic jaws suitable to hold flat and cylindrical workpieces.

Photogallery



DATI DIMENSIONALI

* with prismatic jaws / ** with a flat jaw + prismatic jaw

TYPE	A	B	C	C*	C**	D	E	F	G	H	I	L	M	N	WEIGHT kg
80	82	30	50	45	--	56	25.5	117	10	55	156	230	140	13	4
80 AP.80	82	30	88	80	-	56	25.5	117	10	90	156	270	175	13	4
110	112	40	120	110	115	65	25.5	161	16	100	200	330	240	16.5	8
130	132	40	190	180	185	71	28	184	16	160	230	430	334	18.5	13

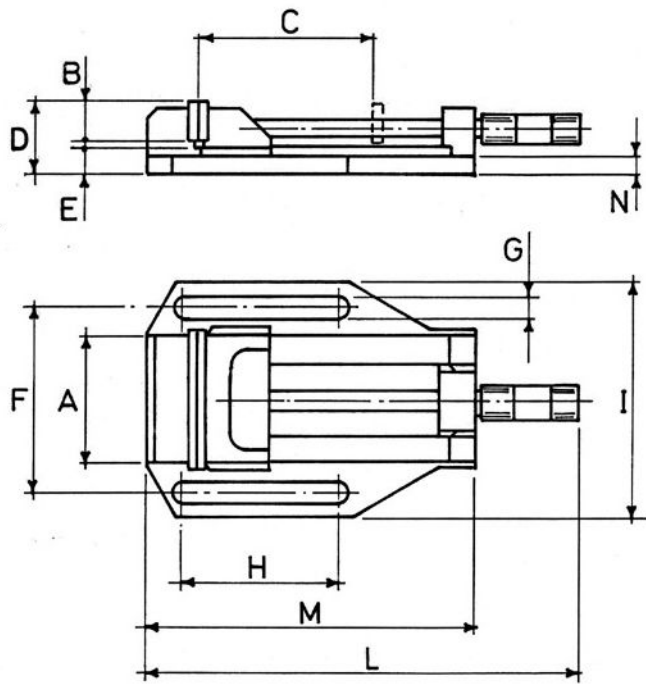

DATI FUNZIONALI

TYPE	P (KN)
80	5
110	12
130	12

